

Low Shear Applications

Truelev

Free Floating Magnetic Mixer



The Truelev Mixer is an astonishing breakthrough in engineering, eliminating all known flaws of previous mixer designs in one giant technological leap! The revolutionary Truelev with its bearing-less fully levitating technology is perfect for shear sensitive products. This product is our high-end mixer that offers a unique control and measuring capability that can be leveraged in all tanks, final drug substance holding tanks or bioreactors

Basic Selection

	ZF100	ZF160
Max Volume at 1 cP [litr]	250	3000
Max Speed [rpm]	350	350

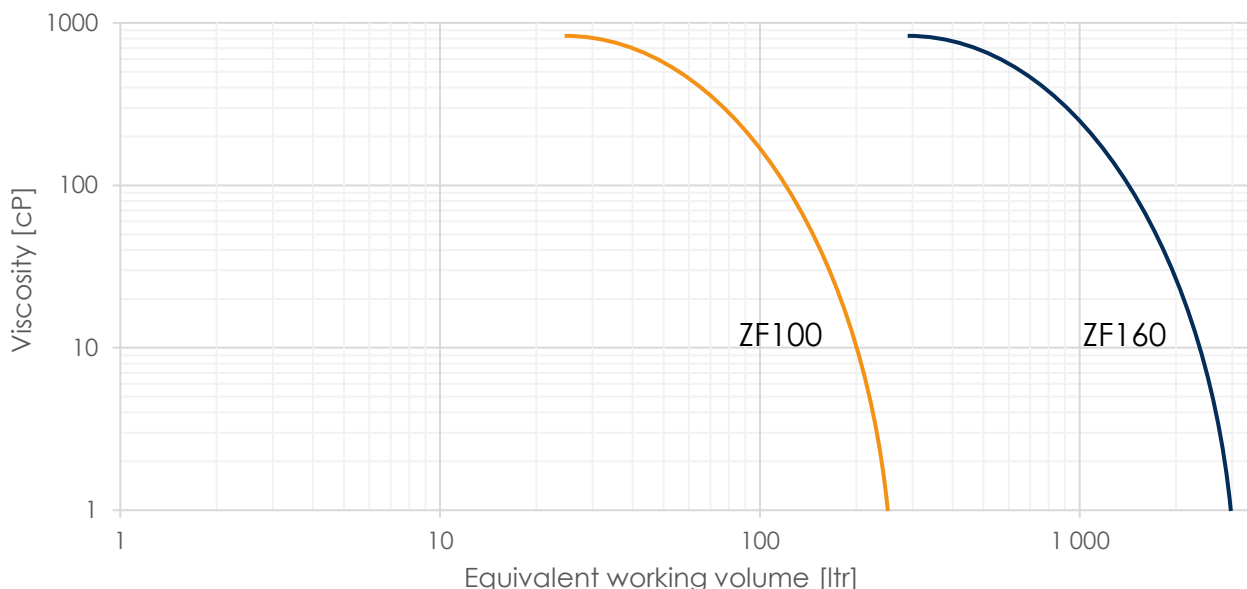

The information in this publication is subject to change without prior notice. The information in this document is believed to be complete and accurate at the time of publication. Metenova assumes no responsibility for any errors that may appear in this document. Customer is responsible for determining Metenova's product will perform suitable in the intended application.

PATENTED

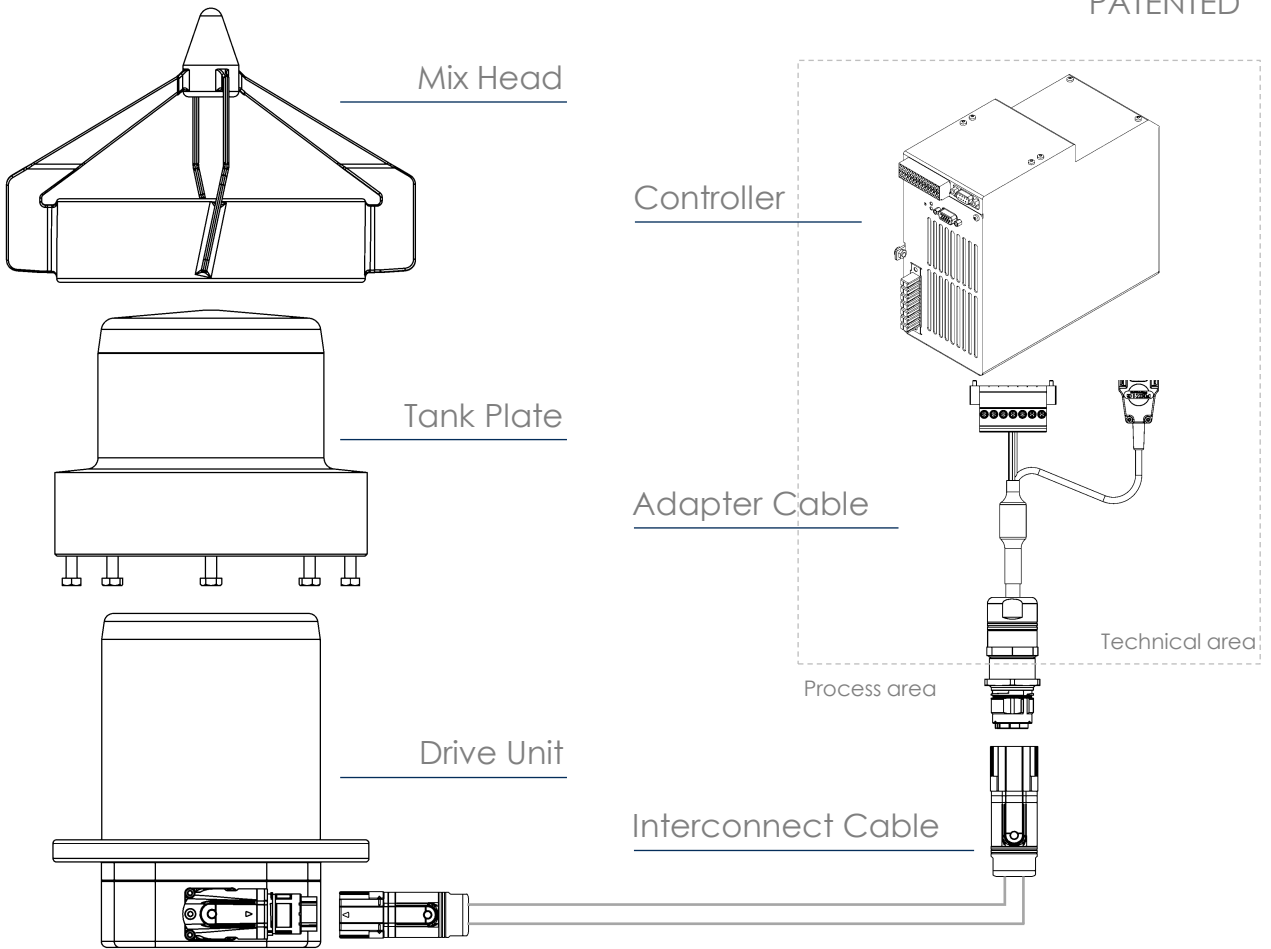

General guide for components detail specification data sheet
(More variation options available for each subcomponent)

Mixer Model	Mixing Head	Tank Plate	Drive Unit	Controller
ZF100	DS ZF100 MH -4718	DS ZF100 TP -3432	DS ZF100 DU -3888	DS ZF100 Controller -4928
ZF160	DS ZF160 MH -2283	DS ZF160 TP -3304	DS ZF160 DU -2434	DS ZF160 Controller -4933

Net Weight (approximate)

Mixer Model	ZF100	ZF160
Weight kg (lb)	5 (11)	13 (29)

Additional information

Operating Temp	5°C - 135°C (41°F - 275°F) Environment Temp 0°C - 40°C (32°F - 104°F)
Operating Pressure	-1 – 7 barg (-14.7 – 103 psig)
Surface Roughness	Ra ≤ 0.38 µm (15 µin)
Surface Treatment	Electro polished. Non animal origin polishing compounds are used.
Product contact material	Standard SS material 316L.