

Zero-g Biomixer

Tank Plate

The Zero-g Biomixer offers an aseptic magnetic multi-stage mixer for gentle mixing. It features Metenovas patented Zero Gravity Technology, minimizing the risk of damaged bearings.

Biotechnology
Applications

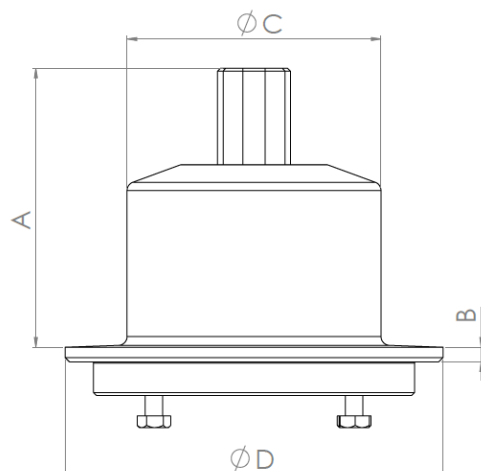

Measurements

Mixer model	Article Number	A mm (in)	B mm (in)	ØC mm (in)	Welding Diameter ØD mm (in)	Weight kg (lb)
ZGB2	ZG13B506-06444	95.5 (3.76)	5 (0.20)	87 (3.43)	129.5 (5.1)	1.6 (3.53)

General Information

Material	Stainless Steel AISI 316L (1.4404) ASME SA-479 EN 10272 (PED) (Other materials are available upon request.)
Certificate	EN10204 3.1
Surface Roughness	Ra ≤ 0.38 µm (15 µin)
Surface Treatment	Manually polished. Non animal origin polishing compounds are used.
Operating Temp	5°C - 150°C (41°F - 302°F)
pH Range	1 – 14
Design Pressure	-1 – 10 barg (-14.5 – 145 psig)

Metenova



www.metenova.com

Phone: +46 (0)31-335 95 00 | +1(908) 537 4199 | E-mail: info@metenova.com

The information in this publication is subject to change without prior notice. The information in this document is believed to be complete and accurate at the time of publication. Metenova assumes no responsibility for any errors that may appear in this document. Customer is responsible for determining Metenova's product will perform suitable in the intended application