

Zero-g Biomixer

Mix Head

The Zero-g Biomixer offers an aseptic magnetic multi-stage mixer for gentle mixing. It features Metenovas patented Zero Gravity Technology, minimizing the risk of damaged bearings.

Biotechnology
Applications

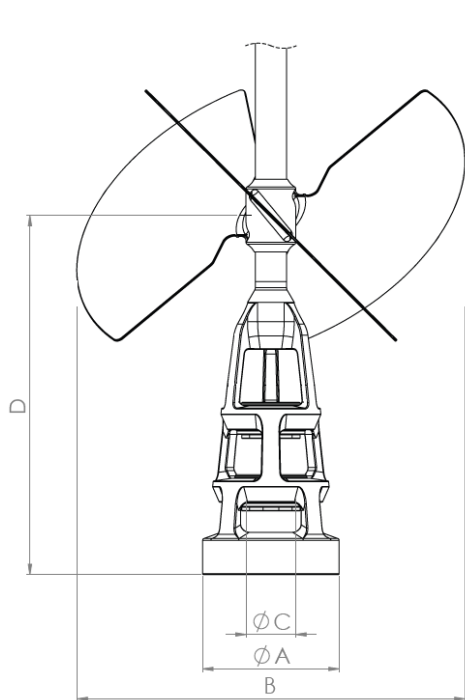

Measurements

Mixer model	ØA mm (in)	B mm (in)	ØC mm (in)	D mm (in)	Weight kg (lb)
ZGB2	131.5 (5.18)	*	48 (1.89)	*	12.5 (27.56)

Options

Other impeller types are available upon request

Welded or height adjustable impellers available

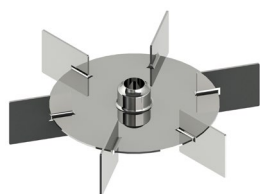

Rushton



Marine

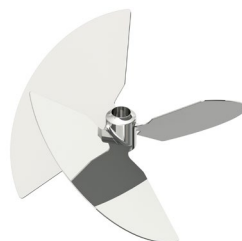

Elephant Ear



Hydrofoil

*) Impeller diameter and positions available dependant on mixer model, mixing speed, impeller type and customer request.

General Information

Material	Stainless Steel 316L / EN 1.4404 (Other materials are available upon request.)
Cert	EN 10204 3.1
Female Sleeve	Silicon Carbide (SiC) FDA CFR21 § 211.65 & USP class VI
O-Rings	EPDM FDA CFR21 § 177.2600 & USP class VI
Surface Roughness	Ra ≤ 0.38 μm (15 μin)
Surface Treatment	Electro polished. Non animal origin polishing compounds are used.
Operating Temp	5°C - 150°C (41°F - 302°F)
Operating Pressure	-1 – 7 barg (-14.5 – 101.5 psig)
pH Range	1 – 14

mete  nova

www.metenova.com

Phone: +46 (0)31-335 95 00 | +1(908) 537 4199 | E-mail: info@metenova.com

The information in this publication is subject to change without prior notice. The information in this document is believed to be complete and accurate at the time of publication. Metenova assumes no responsibility for any errors that may appear in this document. Customer is responsible for determining Metenova's product will perform suitable in the intended application