

Zero-g

Drive Unit AC

Zero-g mixers are the base line of Metenova's mixer program. They are very versatile and covers a vast range of applications all through the process chain.

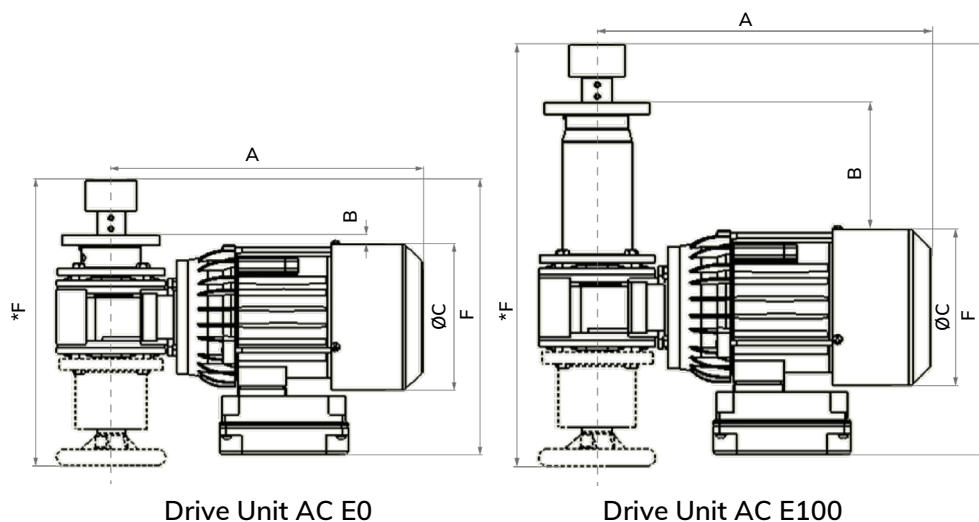

Product Key

Complete Item Number with Versions

ZGXXXXX-[]XXXXX [] = F, I, D, N

Versions

	F	I	D	N
Efficiency Performance Class	IE3	IE3	IE3	IE3
Protection Class	IP55	IP54	IP66	IP66
Forced Cooling	-	Yes	-	Yes

Measurements IP54/IP55

Mixer Model	Article Number	A mm (in)	B mm (in)	ØC mm (in)	F mm (in)	Weight kg (lb)	With Lowering Device	
							*F mm (in)	*Weight kg (lb)
ZG1, ZG2 E0	ZG51502-F00875	231 (9.07)	3 (0.1)	110 (4.33)	219 (8.62)	5.2 (11.55)	269 (10.59)	6.6 (14.48)
ZG1, ZG2 E100	ZG51502-F00980	231 (9.07)	103 (4.1)	110 (4.33)	319 (12.56)	5.8 (12.85)	350 (13.78)	7.4 (16.38)
ZG1, ZG2 E0 Flanged, Dished End	ZG51502-F02542	231 (9.07)	3 (0.1)	110 (4.33)	239 (9.39)	5.2 (11.55)	-	-
ZG3 E0	ZG12502-F00441	244 (9.61)	5 (0.2)	120 (4.72)	227 (8.94)	6.2 (13.76)	252 (9.92)	7.6 (16.80)
ZG3 E0	ZG12502-I00441	297 (11.69)	5 (0.2)	120 (4.72)	227 (8.94)	6.8 (15.08)	252 (9.92)	8.2 (18.12)
ZG3 E100	ZG12502-F00427	244 (9.61)	105 (4.1)	120 (4.72)	327 (12.85)	6.9 (15.30)	352 (13.88)	8.4 (18.41)
ZG3 E100	ZG12502-I00427	297 (11.69)	105 (4.1)	120 (4.72)	327 (12.85)	7.5 (16.62)	352 (13.88)	9.0 (19.73)
ZG5 E0	ZG52502-F00442	286 (11.26)	5 (0.2)	134 (5.28)	251 (9.88)	9.9 (21.91)	261 (10.28)	11.1 (24.36)
ZG5 E0	ZG52502-I00442	326 (12.83)	5 (0.2)	134 (5.28)	251 (9.88)	10.5 (23.24)	261 (10.28)	11.7 (25.68)

*F = F measurement with lowering device (Add-on option 3, see separate article number on page 4)

*Weight = Weight with lowering device



A REPLIGEN COMPANY

Mixer Model	Article Number	A mm (in)	B mm (in)	ØC mm (in)	F mm (in)	Weight kg (lb)	With Lowering Device		
							*F mm (in)	*Weight kg (lb)	
ZG5	E100	ZG52502-F00428	286 (11.26)	105 (4.1)	134 (5.28)	351 (13.82)	11.5 (25.26)	361 (14.23)	12.6 (27.87)
ZG5	E100	ZG52502-I00428	326 (12.83)	105 (4.1)	134 (5.28)	351 (13.82)	12.1 (26.59)	361 (14.23)	13.2 (29.19)
ZG6	E0	ZG13502-F00443	304 (11.97)	3 (0.1)	134 (5.28)	249 (9.80)	11.5 (25.38)	260 (10.24)	12.6 (27.80)
ZG6	E0	ZG13502-I00443	344 (13.54)	3 (0.1)	134 (5.28)	249 (9.80)	12.1 (26.70)	260 (10.24)	13.2 (29.12)
ZG6	E100	ZG13502-F00429	304 (11.97)	103 (4.1)	134 (5.28)	349 (13.76)	13.2 (29.10)	360 (14.17)	14.4 (31.68)
ZG6	E100	ZG13502-I00429	344 (13.54)	103 (4.1)	134 (5.28)	349 (13.76)	13.8 (30.42)	360 (14.17)	15.0 (33.00)
ZG7	E0	ZG23502-F00444	320 (12.61)	21 (0.8)	150 (5.91)	282 (11.10)	15.3 (33.82)	314 (12.36)	17.8 (39.24)
ZG7	E0	ZG23502-I00444	386 (15.21)	21 (0.8)	150 (5.91)	282 (11.10)	15.9 (35.14)	314 (12.36)	18.4 (40.57)
ZG7	E100	ZG23502-F00430	320 (12.61)	121 (4.8)	150 (5.91)	382 (15.06)	16.9 (37.21)	414 (16.30)	19.4 (42.86)
ZG7	E100	ZG23502-I00430	386 (15.21)	121 (4.8)	150 (5.91)	382 (15.06)	17.5 (38.54)	414 (16.30)	20.0 (44.18)
ZG8	E0	ZG53502-F00445	374 (14.72)	26 (1.0)	194 (7.64)	319 (12.56)	29.1 (64.22)	344 (13.54)	31.7 (69.86)
ZG8	E0	ZG53502-I00445	443 (17.44)	26 (1.0)	194 (7.64)	319 (12.56)	29.7 (65.54)	344 (13.54)	32.3 (71.19)
ZG8	E100	ZG53502-F00431	374 (14.72)	126 (5.0)	194 (7.64)	419 (16.50)	31.9 (70.31)	444 (17.50)	34.4 (75.88)
ZG8	E100	ZG53502-I00431	443 (17.44)	126 (5.0)	194 (7.64)	419 (16.50)	32.5 (71.63)	444 (17.50)	35.0 (77.21)
ZG9	E0	ZG14502-F00446	399 (15.71)	26 (1.0)	194 (7.64)	329 (12.95)	35.5 (78.24)	354 (13.94)	38.0 (83.78)
ZG9	E0	ZG14502-I00446	445 (17.52)	26 (1.0)	194 (7.64)	329 (12.95)	36.1 (79.56)	354 (13.94)	38.6 (85.10)
ZG9	E100	ZG14502-F00432	399 (15.71)	126 (5.0)	194 (7.64)	429 (16.89)	38.3 (84.33)	454 (17.89)	40.8 (89.90)
ZG9	E100	ZG14502-I00432	445 (17.52)	126 (5.0)	194 (7.64)	429 (16.89)	38.9 (85.65)	454 (17.89)	41.4 (91.23)
ZG10	E0	ZG24502-F00447	474 (18.64)	16 (0.6)	210 (8.27)	338 (13.31)	50.7 (111.71)	353 (13.90)	52.3 (115.19)
ZG10	E0	ZG24502-I00447	496 (19.51)	16 (0.6)	210 (8.27)	338 (13.31)	51.3 (113.03)	353 (13.90)	52.9 (116.51)
ZG10	E100	ZG24502-F00433	474 (18.64)	116 (4.6)	210 (8.27)	438 (17.24)	54.2 (119.45)	453 (17.83)	55.8 (122.95)
ZG10	E100	ZG24502-I00433	496 (19.51)	116 (4.6)	210 (8.27)	438 (17.24)	54.8 (120.77)	453 (17.83)	56.4 (124.27)

Measurements IP66

Mixer Model	Article Number	A mm (in)	B mm (in)	ØC mm (in)	F mm (in)	Weight kg (lb)	With Lowering Device		
							*F mm (in)	*Weight kg (lb)	
ZG1, ZG2	E0	ZG51502-D00875	231 (9.07)	3 (0.1)	110 (4.33)	219 (8.62)	5.2 (11.55)	269 (10.59)	6.6 (14.48)
ZG1, ZG2	E100	ZG51502-D00980	231 (9.07)	103 (4.1)	110 (4.33)	319 (12.56)	5.8 (12.85)	350 (13.78)	7.4 (16.38)
ZG1, ZG2 Flanged, Dished End	E0	ZG51502-D02542	231 (9.07)	3 (0.1)	110 (4.33)	239 (9.39)	5.2 (11.55)	-	-
ZG3	E0	ZG12502-D00441	244 (9.61)	5 (0.2)	120 (4.72)	227 (8.94)	6.2 (13.76)	252 (9.92)	7.6 (16.80)
ZG3	E0	ZG12502-N00441	349 (13.74)	5 (0.2)	120 (4.72)	227 (8.94)	8.9 (19.71)	252 (9.92)	10.3 (22.75)
ZG3	E100	ZG12502-D00427	244 (9.61)	105 (4.1)	120 (4.72)	327 (12.85)	6.9 (15.30)	352 (13.88)	8.4 (18.41)
ZG3	E100	ZG12502-N00427	349 (13.74)	105 (4.1)	120 (4.72)	327 (12.85)	9.6 (21.25)	352 (13.88)	11.1 (24.36)
ZG5	E0	ZG52502-D00442	286 (11.26)	5 (0.2)	134 (5.28)	251 (9.88)	9.9 (21.91)	261 (10.28)	11.1 (24.36)
ZG5	E0	ZG52502-N00442	388 (15.28)	5 (0.2)	134 (5.28)	251 (9.88)	12.9 (28.53)	261 (10.28)	14.1 (30.97)
ZG5	E100	ZG52502-D00428	286 (11.26)	105 (4.1)	134 (5.28)	351 (13.82)	11.5 (25.26)	361 (14.23)	12.6 (27.87)
ZG5	E100	ZG52502-N00428	388 (15.28)	105 (4.1)	134 (5.28)	351 (13.82)	14.5 (31.88)	361 (14.23)	15.6 (34.48)
ZG6	E0	ZG13502-D00443	304 (11.97)	3 (0.1)	134 (5.28)	249 (9.80)	11.5 (25.38)	260 (10.24)	12.6 (27.80)
ZG6	E0	ZG13502-N00443	406 (15.98)	3 (0.1)	134 (5.28)	249 (9.80)	14.5 (31.99)	260 (10.24)	15.6 (34.41)
ZG6	E100	ZG13502-D00429	304 (11.97)	103 (4.1)	134 (5.28)	349 (13.76)	13.2 (29.10)	360 (14.17)	14.4 (31.68)
ZG6	E100	ZG13502-N00429	406 (15.98)	103 (4.1)	134 (5.28)	349 (13.76)	16.2 (35.71)	360 (14.17)	17.4 (38.29)

*F = F measurement with lowering device (Add-on option 3, see separate article number on page 4)

*Weight = Weight with lowering device

Mixer Model	Article Number	A mm (in)	B mm (in)	ØC mm (in)	F mm (in)	Weight kg (lb)	With Lowering Device		
							*F mm (in)	*Weight kg (lb)	
ZG7	E0	ZG23502-D00444	320 (12.61)	21 (0.8)	150 (5.91)	282 (11.10)	15.3 (33.82)	314 (12.36)	17.8 (39.24)
ZG7	E0	ZG23502-N00444	421 (16.59)	21 (0.8)	150 (5.91)	282 (11.10)	18.5 (40.87)	314 (12.36)	21.0 (46.30)
ZG7	E100	ZG23502-D00430	320 (12.61)	121 (4.8)	150 (5.91)	382 (15.06)	16.9 (37.21)	414 (16.30)	19.4 (42.86)
ZG7	E100	ZG23502-N00430	421 (16.59)	121 (4.8)	150 (5.91)	382 (15.06)	20.1 (44.27)	414 (16.30)	22.6 (49.91)
ZG8	E0	ZG53502-D00445	374 (14.72)	26 (1.0)	194 (7.64)	319 (12.56)	29.1 (64.22)	344 (13.54)	31.7 (69.86)
ZG8	E0	ZG53502-N00445	488 (19.21)	26 (1.0)	194 (7.64)	319 (12.56)	32.6 (71.94)	344 (13.54)	35.2 (77.58)
ZG8	E100	ZG53502-D00431	374 (14.72)	126 (5.0)	194 (7.64)	419 (16.50)	31.9 (70.31)	444 (17.50)	34.4 (75.88)
ZG8	E100	ZG53502-N00431	488 (19.21)	126 (5.0)	194 (7.64)	419 (16.50)	35.4 (78.02)	444 (17.50)	37.9 (83.60)
ZG9	E0	ZG14502-D00446	399 (15.71)	26 (1.0)	194 (7.64)	329 (12.95)	35.5 (78.24)	354 (13.94)	38.0 (83.78)
ZG9	E0	ZG14502-N00446	490 (19.29)	26 (1.0)	194 (7.64)	329 (12.95)	39.0 (85.96)	354 (13.94)	41.5 (91.49)
ZG9	E100	ZG14502-D00432	399 (15.71)	126 (5.0)	194 (7.64)	429 (16.89)	38.3 (84.33)	454 (17.89)	40.8 (89.90)
ZG9	E100	ZG14502-N00432	490 (19.29)	126 (5.0)	194 (7.64)	429 (16.89)	41.8 (92.04)	454 (17.89)	44.3 (97.62)
ZG10	E0	ZG24502-D00447	474 (18.64)	16 (0.6)	210 (8.27)	338 (13.31)	50.7 (111.71)	353 (13.90)	52.3 (115.19)
ZG10	E0	ZG24502-N00447	545 (21.44)	16 (0.6)	210 (8.27)	338 (13.31)	54.4 (119.87)	353 (13.90)	56.0 (123.35)
ZG10	E100	ZG24502-D00433	474 (18.64)	116 (4.6)	210 (8.27)	438 (17.24)	54.2 (119.45)	453 (17.83)	55.8 (122.95)
ZG10	E100	ZG24502-N00433	545 (21.44)	116 (4.6)	210 (8.27)	438 (17.24)	57.9 (127.60)	453 (17.83)	59.5 (131.11)

*F = F measurement with lowering device (Add-on option 3, see separate article number on page 4)

*Weight = Weight with lowering device

General Information

Voltage	Δ230 / Y400 VAC @ 50Hz / Y460 VAC @ 60Hz (±5%)
Thermal Protection	PTC thermistors
Forced Cooling Power Supply	Δ230 VAC
Certified for Incorporation	
Environment Temperature	0°C - 40°C (32°F - 104°F)
Paint	In compliance with FDA
Gear Box Oil	Food grade in compliance with FDA
Cooling Type	TEFC (Totally Enclosed, Fan-Cooled)
Motor support	Due to heavy weight, extra support is necessary for sizes ZG8 and above.
Packing and Marking	Items are individually packed and for traceability purposes marked with item & id no.
Quality Assurance	Metenova Quality Assurance system ensures the quality and traceability at all stages of the process.

Product Specific Information IP54/IP55 and IP66

Mixer Model	Motor	Poles	Gear Box	Current	Min-Max rpm for Mixer
ZG1, ZG2	0.12 kW/ 0.17 hp @ 50Hz 0.14 kW/ 0.19 hp @ 60Hz	2-pole	7:1	0.65A @ 230V/50Hz – 0.38A @ 400V/50Hz – 0.38A @ 460V/60Hz	50* - 490
ZG3	0.25 kW/ 0.33 hp @ 50 Hz 0.29 kW/ 0.38 hp @ 60 Hz	2-pole	7:1	1.10A @ 230V/50Hz – 0.65A @ 400V/50Hz – 0.65A @ 460V/60Hz	50* - 490
ZG5	0.37 kW/ 0.50 hp @ 50 Hz 0.43 kW/ 0.57 hp @ 60 Hz	2-pole	7:1	1.65A @ 230V/50Hz – 0.95A @ 400V/50Hz – 0.95A @ 460V/60Hz	50* - 490
ZG6	0.55 kW/ 0.75 hp @ 50 Hz 0.64 kW/ 0.86 hp @ 60 Hz	2-pole	7:1	2.15A @ 230V/50Hz – 1.25A @ 400V/50Hz – 1.25A @ 460V/60H	50* - 490
ZG7	0.75 kW/ 1.0 hp @ 50 Hz 0.87 kW/ 1.17 hp @ 60 Hz	2-pole	7:1	2.95A @ 230V/50Hz – 1.70A @ 400V/50Hz – 1.70A @ 460V/60Hz	50* - 490
ZG8	2.2 kW/ 2.95 hp @ 50 Hz 2.5 kW/ 3.35 hp @ 60 Hz	2-pole	10:1	7.5A @ 230V/50Hz – 4.3A @ 400V/50Hz – 4.1A @ 460V/60Hz	34* - 343
ZG9	1.5 kW/ 2.0 hp @ 50 Hz 1.7 kW/ 2.3 hp @ 60 Hz	4-pole	7:1	5.7A @ 230V/50Hz – 3.3A @ 400V/50Hz – 3.2A @ 460V/60Hz	24* - 245
ZG10	3.0 kW/ 4.0 hp @ 50 Hz 3.6 kW/ 4.8 hp @ 60 Hz	4-pole	7:1	10.9A @ 230V/50Hz – 6.3A @ 400V/50Hz – 6.3A @ 460V/60Hz	24* - 245

*When forced cooling is used, the minimum speed is 0 Hz

Options

Option 1



Option 2



Option 3



Option 4



RPM Sensor,
Mix Head

RPM Sensor, Shaft

Lowering Device

Transport
Locking Device

Mixer
Model

E0 & E100

E0

E100

E0*

E100

E0 & E100

Mixer Model	E0 & E100	E0	E100	E0*	E100	E0 & E100
ZG1, ZG2	-	ZG00014-03193	ZG00014-03193	ZG51502-04147	ZG51502-04148	ZG00016-01773
ZG3	ZG00014-03083	ZG00014-03193	ZG00014-03193	ZG12502-03638	ZG12502-03639	ZG12016-01775
ZG5	ZG00014-03083	ZG00014-03193	ZG00014-03193	ZG52502-02000	ZG52502-02001	ZG52016-01776
ZG6	ZG00014-03083	ZG00014-03193	ZG00014-03193	ZG13502-02002	ZG13502-02003	ZG13016-01777
ZG7	ZG00014-03083	ZG00014-03193	ZG00014-03193	ZG23502-02006	ZG23502-02007	ZG23016-02721
ZG8	ZG00014-03083	-	ZG00014-03193	ZG53502-02008	ZG53502-02009	-
ZG9	ZG00014-03083	-	ZG00014-03193	ZG14502-02010	ZG14502-02011	-
ZG10	ZG00014-03083	-	ZG00014-03193	ZG24502-02012	ZG24502-02013	-

*Not possible to combine with RPM Sensor, Shaft

RPM Sensor

Article Number	ZG00014-03083	ZG00014-03193
Type	RPM Sensor, Mix Head	RPM Sensor, Shaft
Pulses/Turn	1	4
Output Function	3-wire, NO contact PNP	4-wire, NO/NC contact PNP
Indicator	Yellow LED	Yellow LED
Temperatur Range	-25°C - 70°C (-13°F - 158°F)	-25°C - 70°C (-13°F - 158°F)
Operations Voltage	10...65 VDC	10...30 VDC
Protection Class	IP67	IP67

mete  nova

A REPLIGEN COMPANY

Metenova AB
Norra Ågatan 32, SE-43135
Mölnådal, Sweden
Phone +46(0)31 3359500
www.metenova.com
info@metenova.com

Metenova America INC
P.O Box 398
Glen Gardner, NJ 08826
USA
Phone +1(908)537 4199
info@metenova.com

The information in this publication is subject to change without prior notice. The information in this document is believed to be complete and accurate at the time of publication. Metenova assumes no responsibility for any errors that may appear in this document. Customer is responsible for determining Metenova's product will perform suitable in the intended application