

# Zero-g

## Mix Head

General  
Mixing  
Applications

Zero-g mixers are the base line of Metenovas mixer program. They are very versatile and covers a vast range of applications all through the process chain.

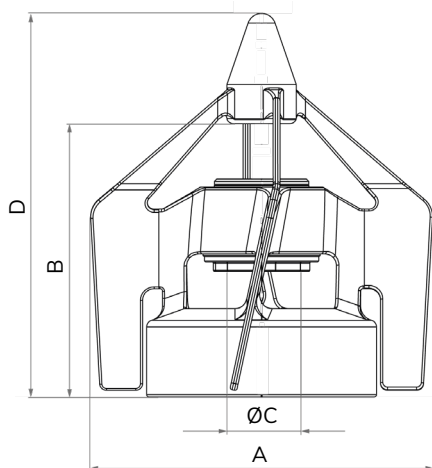

### Measurements

Mixer model	Article Number	A mm (in)	B mm (in)	ØC mm (in)	D mm (in)	Weight kg (lb)
ZG1	ZG05509-01117	70 (2.76)	70.5 (2.78)	18 (0.71)	86.5 (3.41)	0.6 (1.3)
ZG2	ZG51509-00940	96 (3.78)	70.5 (2.78)	18 (0.71)	86.5 (3.41)	0.7 (1.5)
ZG3	ZG12509-00418	117 (4.61)	108.5 (4.27)	32 (1.26)	156.3 (6.15)	1.6 (3.5)
ZG5	ZG52509-00419	148 (5.83)	118.5 (4.67)	32 (1.26)	166.3 (6.55)	2.1 (4.6)
ZG6	ZG13509-00420	160 (6.30)	119.8 (4.72)	32 (1.26)	167.6 (6.60)	2.4 (5.3)
ZG7	ZG23509-00421	177 (6.97)	123.5 (4.86)	32 (1.26)	171.3 (6.74)	2.5 (5.5)
ZG8	ZG53509-00422	236 (9.29)	131.0 (5.16)	40 (1.57)	193.0 (7.60)	3.5 (7.7)
ZG9	ZG14509-00423	300 (11.81)	143.0 (5.63)	40 (1.57)	205.0 (8.07)	5.0 (11.0)
ZG10	ZG24509-00424	350 (13.78)	148.5 (5.85)	40 (1.57)	210.5 (8.29)	5.8 (12.8)
ZG11	ZG34509-06726	385 (15.16)	240.5 (9.47)	48 (1.89)	338 (13.31)	10.4 (23.0)

### General Information

Material	Stainless Steel 316L/ EN 1.4404 (Other materials are available upon request).
Inspection Certificate	EN 10204 Type 3.1
Female Sleeve	Silicon Carbide (SSiC) FDA CFR21 & USP class VI
O-Rings	EPDM; FDA CFR21 §177.2600 & USP class VI
Surface Roughness	Ra ≤ 0.38 µm (15 µin)
Surface Treatment	Electropolished. Non animal origin polishing compounds are used.
Operating Temperature	5°C - 150°C (41°F - 302°F)
Design Pressure	-1 – 10 barg (-14.5 – 145 psig)
Operating Pressure	-1 – 7 barg (-14.5 – 101.5 psig)
Packing and Marking	Items are individually packed and for traceability purposes marked with item & id no.
Quality Assurance	Metenova Quality Assurance system ensures the quality and traceability at all stages of the process.

mete  nova

A REPLIGEN COMPANY

## Product key

### Complete item number with add-on

ZGXXXXX-[ ]XXXXX [ ]= 0, A, B, C, D, E

Material Code	Standard Material
0	Stainless Steel ASME TP 316L acc. to SA-479 & EN 1.4404 acc. to EN 10272 UNS S31603
<b>Optional Material (Add on)</b>	
A	Stainless Steel ASME TP 316L acc. to SA-479 UNS S31603; EN 1.4435 acc. to EN 10272 (PED)
B	Stainless Steel 904L/EN 1.4539 ASME SB-649 UNS N08904; EN10272 (PED)
C	Alloy C-22 acc to ASME SB-574 UNS N06022; W.nr 2.4602
D	Alloy C-276 acc to ASME SB-574 UNS N10276; W.nr 2.4819
E	AL-6XN UNS N08367; ASME SB-694

## Options

Mixer model	Option 1 Silicone platinum cured O-rings in lieu of EPDM	Option 2 Viton O-rings in lieu of EPDM	Option 3 Kalrez O-rings in lieu of EPDM
ZG1	ZG00013-04173	ZG00013-03130	ZG00013-03136
ZG2	ZG00013-04173	ZG00013-03130	ZG00013-03136
ZG3	ZG00013-04174	ZG00013-03131	ZG00013-03137
ZG5	ZG00013-04174	ZG00013-03131	ZG00013-03137
ZG6	ZG00013-04174	ZG00013-03131	ZG00013-03137
ZG7	ZG00013-04174	ZG00013-03131	ZG00013-03137
ZG8	ZG00013-04175	ZG00013-03132	ZG00013-03138
ZG9	ZG00013-04175	ZG00013-03132	ZG00013-03138
ZG10	ZG00013-04175	ZG00013-03132	ZG00013-03138
ZG11	*	*	*

\* Available upon request

## Tools specification datasheet

### Lifting Tool

DS-022

mete  nova

A REPLIGEN COMPANY

Metenova AB  
Norra Ågatan 32, SE-43135  
Mölnådal, Sweden  
Phone +46(0)31 3359500  
www.metenova.com  
info@metenova.com

Metenova America INC  
P.O Box 398  
Glen Gardner, NJ 08826  
USA  
Phone +1(908)537 4199  
info@metenova.com

The information in this publication is subject to change without prior notice. The information in this document is believed to be complete and accurate at the time of publication. Metenova assumes no responsibility for any errors that may appear in this document. Customer is responsible for determining Metenova's product will perform suitable in the intended application